

# **SOLUTIONS@SOURCE**

## *Home Improvement Guidelines*



GEN-HOME\_IMP\_V01\_100910



Enhanced  
Performance

## CONTENTS

Primary Packaging recommendations for **non metallic** products in **non metallic** packaging.

Plastic Tubs, or Carton Boxes etc. Page 3

Poly Bag Hang Tab Page 4

Secondary Packaging recommendations for **non metallic** products in **non metallic** packaging.

5 Side Boxes Page 5

4 Side Boxes Page 6

Blister Packs Page 7

Plastic Tubs etc. Page 8

Shrink Wrapping Page 9

Plastic Cases Page 10

Metal Cases Page 11

Primary Packaging recommendations for **metallic** products in **non metallic** packaging.

Metallic packaging Page 12

Poly Bag Hang Tab Page 13

Secondary Packaging recommendations for **metallic** products in **metallic** or **non metallic** packaging

5 Side Boxes Page 14

4 Side Boxes Page 15

Blister Packs Page 16

Plastic Tubs Page 17

Plastic Cases Page 18

Metal Cases Page 19

If you have any doubts regarding the suitability of any consumer product or its packaging for RF Source Tagging, please contact your local Checkpoint representative





## PRIMARY PACKAGING

### Recommendations for **non metallic** products in **non metallic** packaging Plastic Tubs, or Carton Boxes etc.

The following recommendations are for non metallic products with non metallic packaging e.g. no metal casing, metal foil, metallic ink flood coating, metal back paper etc.

For optimum performance, RF labels should never be applied directly to, or positioned against, metallic or high metal content materials.

Where metallic materials are used for packaging presentation, they should be replaced with Iridine® or MiraFoil® coated materials, or with plain non metallic printed carton or plastic, which allows the RF label to function correctly.

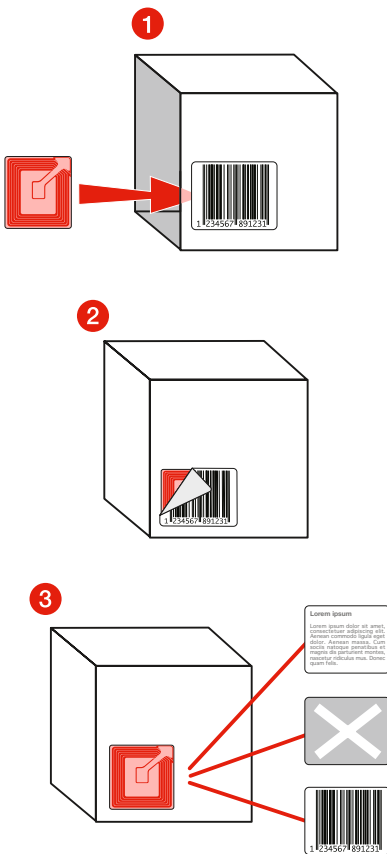

- 1 Space permitting, RF labels can be applied to the inside of product packaging.
- 2 Alternatively, the RF label can be fixed to the outside and covered with the product or barcode label.
- 3 RF labels can also be directly overprinted with variable data to replace the existing barcode label, or with brand information, user instructions or warnings, and applied to the outside of the product packaging.

**IMPORTANT:** Where possible, the RF label should be positioned on the same plane as, and **ALWAYS** within 10 cms (4”) of, the product barcode, preferably directly behind it.

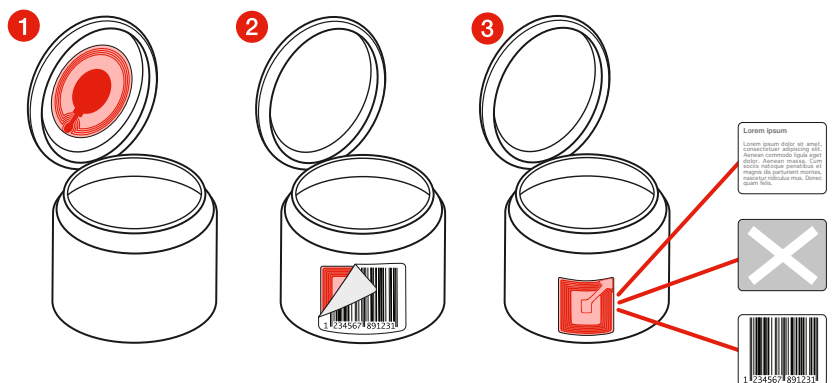

If you have any doubts regarding the suitability of any consumer product or its packaging for RF Source Tagging, please contact your local Checkpoint representative





## PRIMARY PACKAGING

### Recommendations for **non metallic** products in **non metallic** packaging Poly Bag Hang Tab

The following recommendations are for non metallic products with non metallic packaging e.g. no metal casing, metal foil, metallic ink flood coating, metal back paper etc.

For optimum performance, RF labels should never be applied directly to, or positioned against, metallic or high metal content materials.

Where metallic materials are used for packaging presentation, they should be replaced with Iridine® or MiraFoil® coated materials, or with plain non metallic printed carton or plastic, which allows the RF label to function correctly.

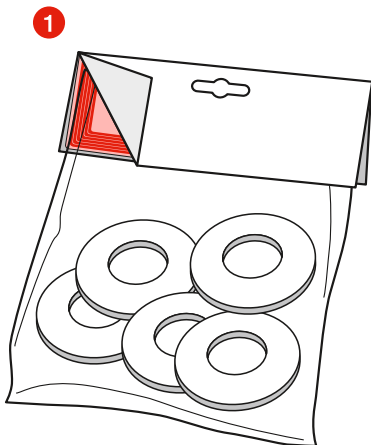

- 1 The RF label should be integrated inside the carton presentation card, making the protection invisible and improving the effectiveness of the tagging process.
- 2 Alternatively, the RF label can be fixed to the outside and covered with the product or barcode label.
- 3 RF labels can also be overprinted with variable data, brand information, user instructions or warnings and applied to the outside of the hang tab.

**IMPORTANT:** Where possible, the RF label should be positioned on the same plane as, and **ALWAYS** within 10 cms (4") of, the product barcode, preferably directly behind it.

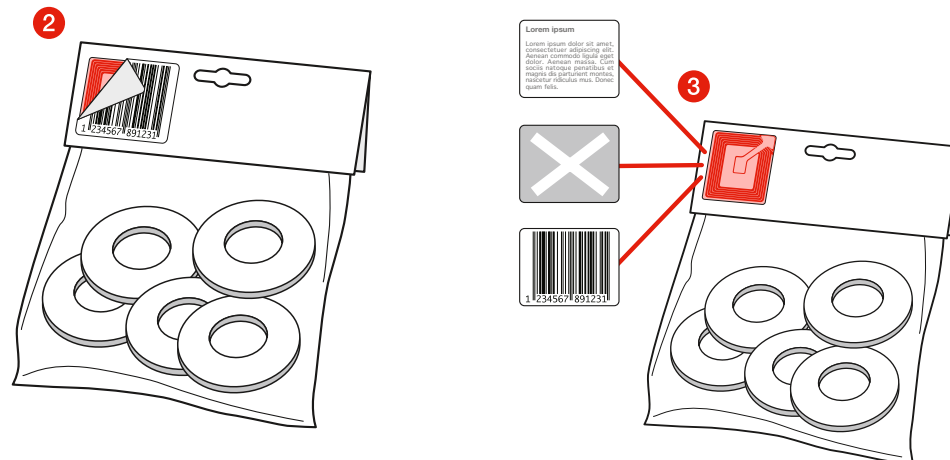

If you have any doubts regarding the suitability of any consumer product or its packaging for RF Source Tagging, please contact your local Checkpoint representative





## SECONDARY PACKAGING

### Recommendations for **non metallic** products in **non metallic** packaging 5 Side Boxes

The following recommendations are for non metallic products with non metallic packaging e.g. no metal casing, metal foil, metallic ink flood coating, metal back paper etc.

To ensure optimum performance, RF labels should never be applied directly to, or positioned against, metallic or high metal content materials.

Where metal foil or metallic ink flood coating is used for packaging presentation, it should be replaced with Iriodine® or MiraFoil® coated materials, or plain non metallic printed carton, that allows the RF label to function correctly.

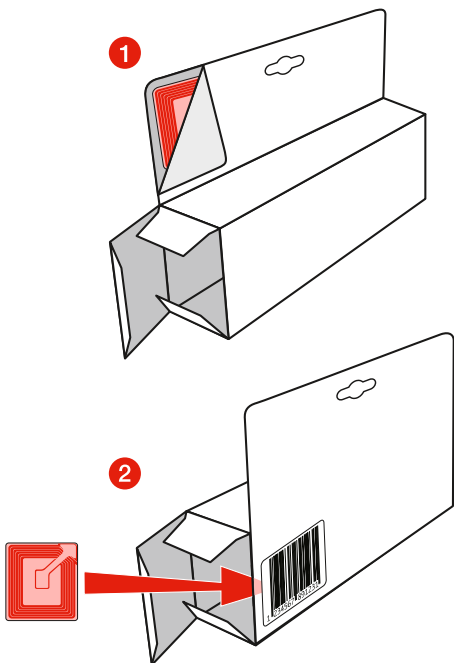

- 1 The RF label should be integrated into the fifth side of the packaging or 2 applied to the inside of the carton packaging, making the protection invisible and improving the effectiveness of the tagging process.
- 3 Alternatively, the RF label can be fixed to the outside and covered with the product or barcode label.
- 4 RF labels can also be overprinted with variable data, brand information, user instructions or warnings and applied directly to the outside of the product packaging.
- 5 In all cases Checkpoint recommends that any packaging be protected using an ultrasonically sealed security blister, to reduce the risk of tampering.

**IMPORTANT:** Where possible, the RF label should be positioned on the same plane as, and **ALWAYS** within 10 cms (4”) of, the product barcode, preferably directly behind it.

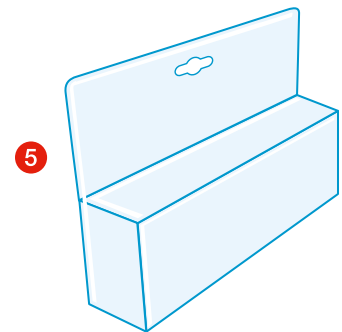
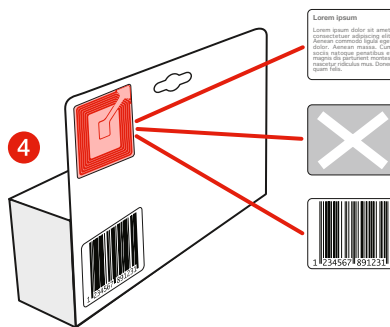
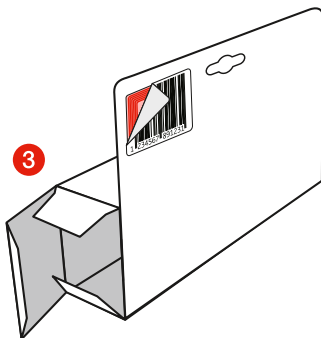

If you have any doubts regarding the suitability of any consumer product or its packaging for RF Source Tagging, please contact your local Checkpoint representative



## SECONDARY PACKAGING

### Recommendations for **non metallic** products in **non metallic** packaging 4 Side Boxes

The following recommendations are for non metallic products with non metallic packaging e.g. no metal casing, metal foil, metallic ink flood coating, metal back paper etc.

To ensure optimum performance, RF labels should never be applied directly to, or positioned against, metallic or high metal content materials.

Where metal foil or metallic ink flood coating is used for packaging presentation, it should be replaced with Iriodine® or MiraFoi® coated materials, or plain non metallic printed carton, that allows the RF label to function correctly.

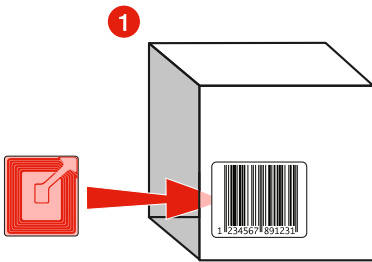

1 The RF label should be applied inside the carton box, making the protection invisible and improving the effectiveness of the tagging process.

2 Alternatively, the RF label can be fixed to the outside and covered with the product or barcode label.

3 RF labels can also be overprinted with variable data, brand information, user instructions or warnings and applied directly to the outside of the product packaging.

**IMPORTANT:** Where possible, the RF label should be positioned on the same plane as, and **ALWAYS** within 10 cms (4") of, the product barcode, preferably directly behind it.

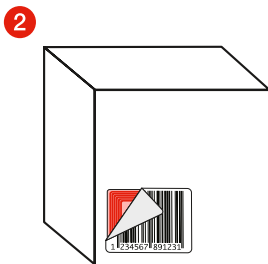

4 In all cases Checkpoint recommends that any packaging be protected using an ultrasonically sealed security blister, to reduce the risk of tampering.

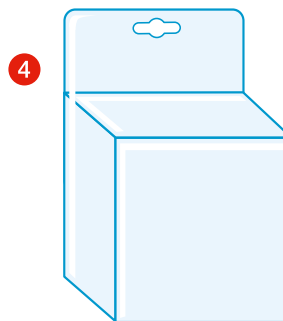
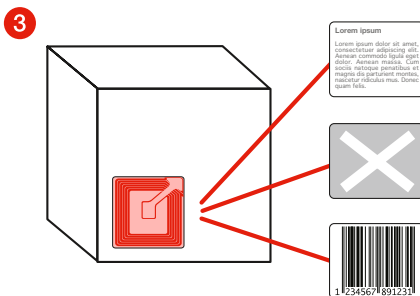

If you have any doubts regarding the suitability of any consumer product or its packaging for RF Source Tagging, please contact your local Checkpoint representative





## SECONDARY PACKAGING

### Recommendations for **non metallic** products in **non metallic** packaging Blister Packs

The following recommendations are for non metallic products with non metallic packaging e.g. no metal casing, metal foil, metallic ink flood coating, metal back paper etc.

To ensure optimum performance, RF labels should never be applied directly to, or positioned against, metallic or high metal content materials.

Where metal foil or metallic ink flood coating is used for packaging presentation, it should be replaced with Iriodine® or MiraFoil® coated materials, or plain non metallic printed carton, that allows the RF label to function correctly.

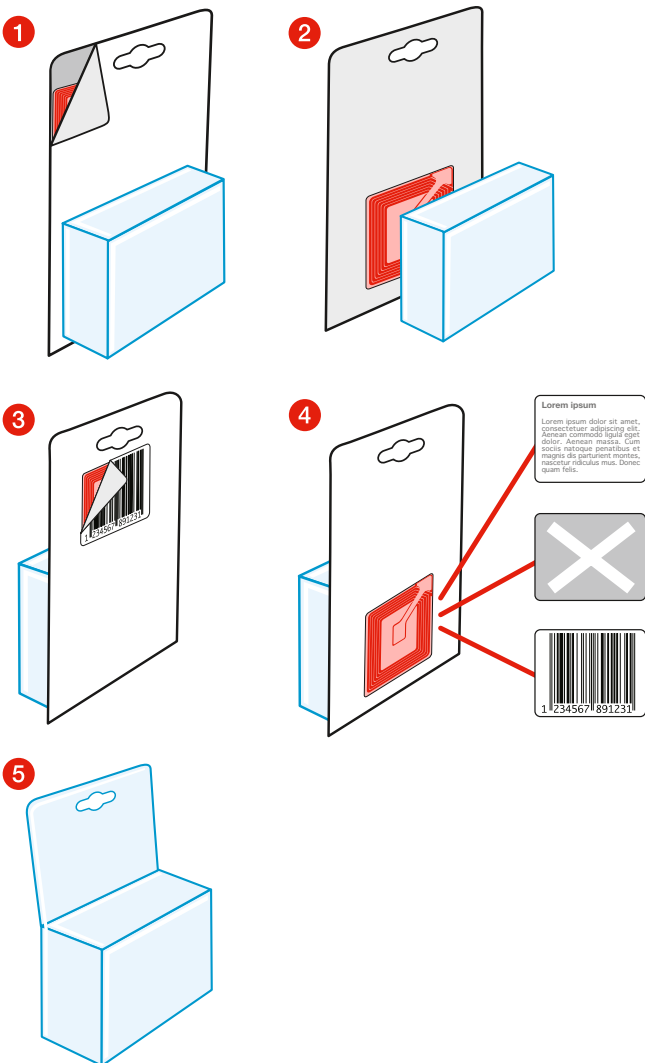

- 1 The RF label should be integrated inside the carton presentation card, making the protection invisible and improving the effectiveness of the tagging process.
- 2 If this is not possible the RF label can be placed behind the product inside the blister.
- 3 Alternatively, the RF label can be fixed to the outside and covered with the product or barcode label.
- 4 RF labels can also be overprinted with variable data, brand information, user instructions or warnings and applied directly to the outside of the blister packaging.

**IMPORTANT:** Where possible, the RF label should be positioned on the same plane as, and ALWAYS within 10 cms (4”) of, the product barcode, preferably directly behind it.

- 5 In all cases Checkpoint recommends that any packaging be protected using an ultrasonically sealed security blister, to reduce the risk of tampering.

If you have any doubts regarding the suitability of any consumer product or its packaging for RF Source Tagging, please contact your local Checkpoint representative





Enhanced Performance

## SECONDARY PACKAGING

### Recommendations for **non metallic** products in **non metallic** packaging Plastic Tubs

The following recommendations are for non metallic products with non metallic packaging e.g. no metal casing, metal foil, metallic ink flood coating, metal back paper etc.

To ensure optimum performance, RF labels should never be applied directly to, or positioned against, metallic or high metal content materials.

Where metal foil or metallic ink flood coating is used for packaging presentation, it should be replaced with Iriodine® or MiraFoil® coated materials, or plain non metallic printed carton, that allows the RF label to function correctly.

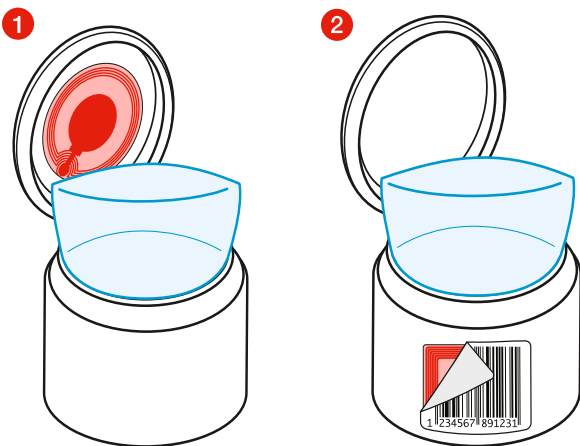

- 1 Space permitting, RF labels can be applied to the inside of product packaging.
- 2 Alternatively, the RF label can be fixed to the outside and covered with the product or barcode label.
- 3 RF labels can also be overprinted with variable data, brand information, user instructions or warnings and applied to the outside of the carton packaging.

**IMPORTANT:** Where possible, the RF label should be positioned on the same plane as, and **ALWAYS** within 10 cms (4”) of, the product barcode, preferably directly behind it.

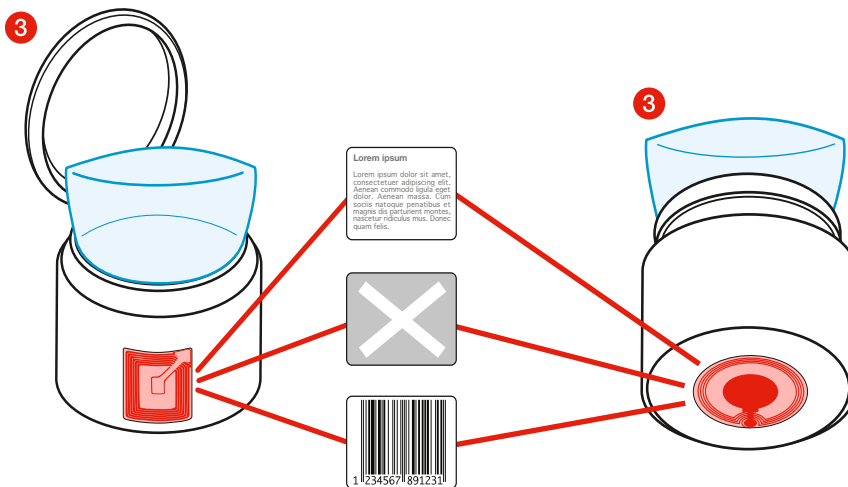

If you have any doubts regarding the suitability of any consumer product or its packaging for RF Source Tagging, please contact your local Checkpoint representative





## SECONDARY PACKAGING

### Recommendations for **non metallic** products in **non metallic** packaging Shrink Wrapped Packaging

The following recommendations are for non metallic products with non metallic packaging e.g. no metal casing, metal foil, metallic ink flood coating, metal back paper etc.

For optimum performance, RF labels should never be applied directly to, or positioned against, metallic or high metal content materials.

Where metallic materials are used for packaging presentation, they should be replaced with Iridine® or MiraFoil® coated materials, or with plain non metallic printed carton or plastic, which allows the RF label to function correctly.

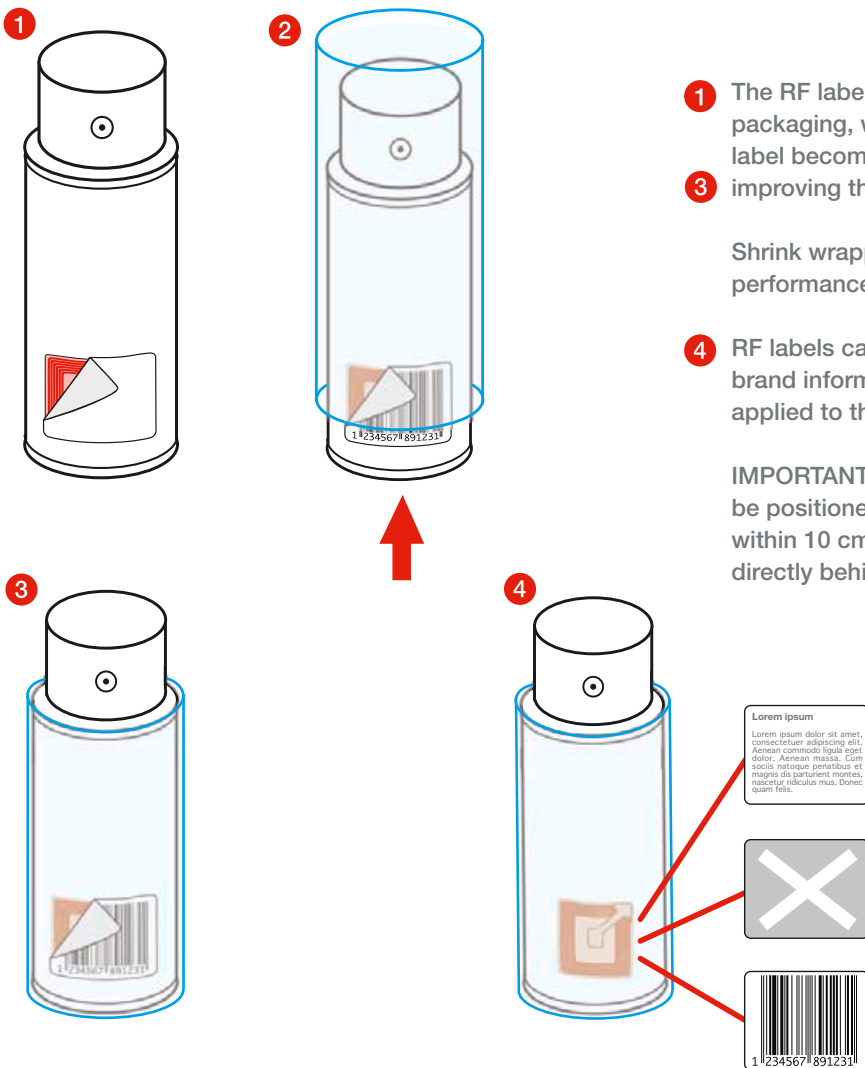

- 1 The RF label should be placed on the product primary packaging, when the shrink wrap is applied, 2 the label becomes invisible and virtually tamper free, 3 improving the effectiveness of the tagging process.

Shrink wrapping has no negative effect on RF label performance.

- 4 RF labels can also be overprinted with variable data, brand information, user instructions or warnings and applied to the outside of the carton packaging.

**IMPORTANT:** Where possible, the RF label should be positioned on the same plane as, and ALWAYS within 10 cms (4") of, the product barcode, preferably directly behind it.

If you have any doubts regarding the suitability of any consumer product or its packaging for RF Source Tagging, please contact your local Checkpoint representative





## SECONDARY PACKAGING

### Recommendations for **non metallic** products in **non metallic** packaging Plastic Carry Cases

The following recommendations are for non metallic products with non metallic packaging e.g. no metal casing, metal foil, metallic ink flood coating, metal back paper etc.

To ensure optimum performance, RF labels should never be applied directly to, or positioned against, metallic or high metal content materials.

Where metal foil or metallic ink flood coating is used for packaging presentation, it should be replaced with Iriodine® or MiraFoil® coated materials that allow the RF label to function correctly.

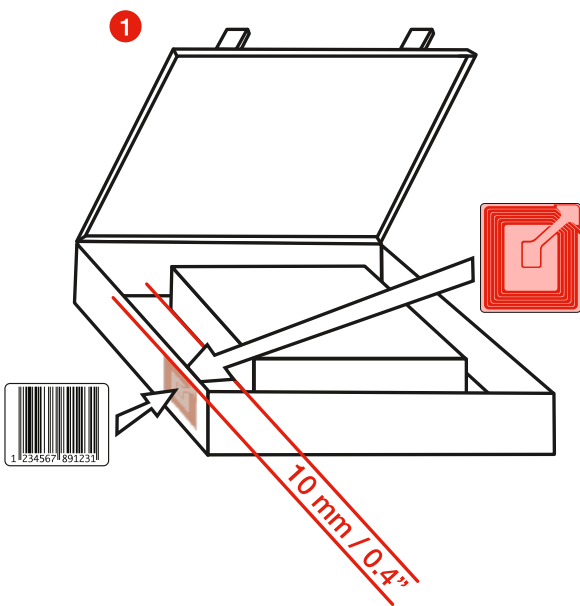

- 1 Products presented in plastic carry cases are typically tagged by fixing an RF label to the inside wall of the case directly behind or within 10 cms (4") of the barcode position. Care should be taken to ensure no metal parts are within 10 mm of the RF label.
- 2 Alternatively, the RF label can be fixed to the outside and covered with the product or barcode label.
- 3 RF labels can also be overprinted with variable data, brand information, user instructions or warnings and applied to the outside of the plastic case.

**IMPORTANT:** Where possible, the RF label should be positioned on the same plane as, and **ALWAYS** within 10 cms (4") of, the product barcode, preferably directly behind it.

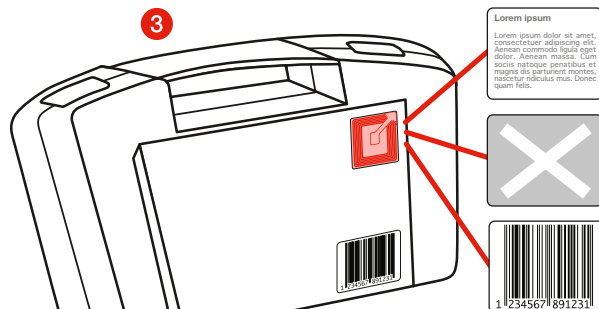
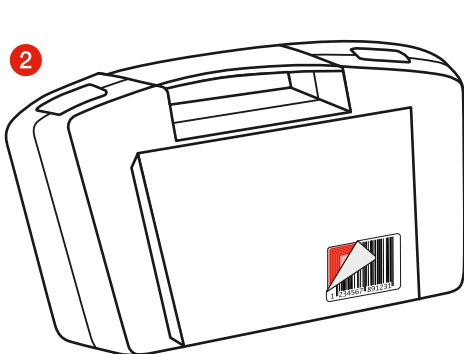

If you have any doubts regarding the suitability of any consumer product or its packaging for RF Source Tagging, please contact your local Checkpoint representative





Enhanced Performance

## SECONDARY PACKAGING

### Recommendations for **non metallic** products in **metallic** packaging Metal Carry Cases

#### Important

Please note that metal carry cases must **not be protected** using standard RF labels.

To ensure optimum performance, RF labels should never be applied directly to, or positioned against, metallic or high metal content materials.

If metal carry cases must be used for presenting merchandise then the form of protection to be used is a loop or lanyard hard tag.

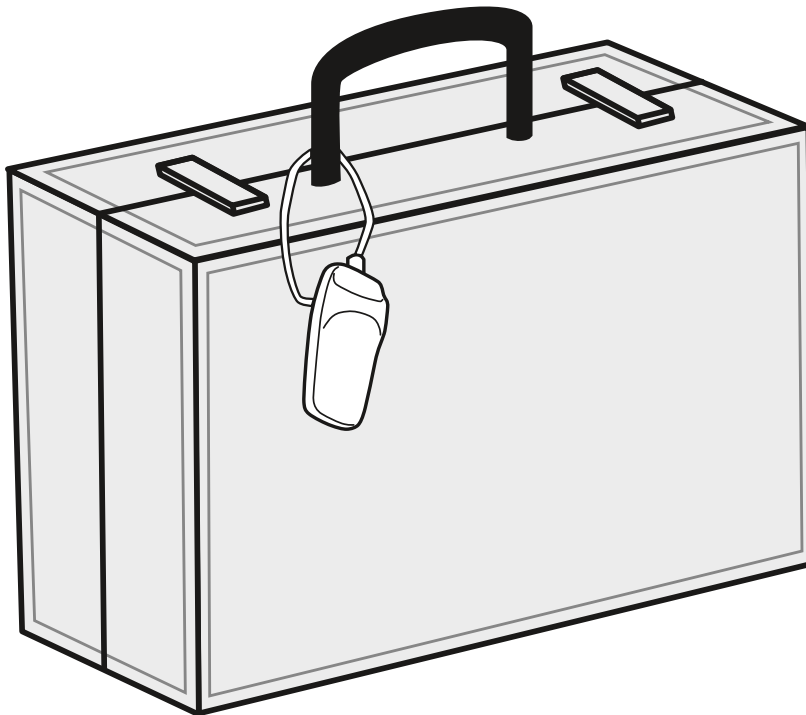

If you have any doubts regarding the suitability of any consumer product or its packaging for RF Source Tagging, please contact your local Checkpoint representative





## PRIMARY PACKAGING

### Recommendations for **metallic** products in **non metallic** packaging Plastic Tubs, Carton Boxes etc.

The following recommendations are for non metallic products with non metallic secondary packaging e.g. no metal casing, metal foil, metallic ink flood coating, metal back paper etc.

For optimum performance, RF labels should never be applied directly to, or positioned against, metallic or high metal content materials.

Where metallic materials are used for packaging presentation, they should be replaced with Iridine® or MiraFoil® coated materials, or with plain non metallic printed carton or plastic, which allows the RF label to function correctly.

If this is not possible then the source tagging process should focus on the product secondary packaging – i.e. its pre-sentation box or blister.

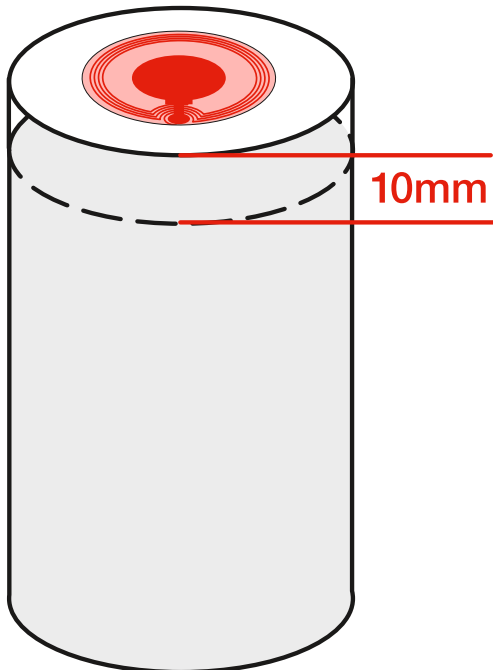

In the case of metallic products, the RF label must be separated by at least 10 mms using either a foam or carton insert to prevent contact between the product and the RF label.

If this cannot be done, consult your Checkpoint representative for product evaluation and correct positioning.

**IMPORTANT:** Where possible, the RF label should be positioned on the same plane as, and **ALWAYS** within 10 cms (4”) of, the product barcode, preferably directly behind it.

If you have any doubts regarding the suitability of any consumer product or its packaging for RF Source Tagging, please contact your local Checkpoint representative





Enhanced Performance

## PRIMARY PACKAGING

### Recommendations for **metallic** products in **non metallic** packaging Poly Bag Hang Tab

The following recommendations are for metallic products with non metallic secondary packaging e.g. no metal casing, metal foil, metallic ink flood coating, metal back paper etc.

For optimum performance, RF labels should never be applied directly to, or positioned against, metallic or high metal content materials.

Where metallic materials are used for packaging presentation, they should be replaced with Iridine® or MiraFoil® coated materials, or with plain non metallic printed carton or plastic, which allows the RF label to function correctly.

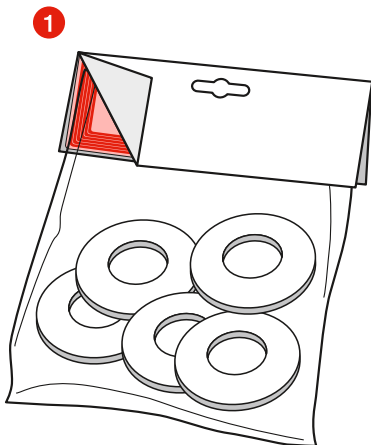

- 1 The RF label should be integrated inside the hang tab, making the protection invisible and improving the effectiveness of the tagging process.
- 2 Alternatively, the RF label can be fixed to the outside and covered with the product or barcode label.
- 3 RF labels can also be overprinted with variable data, brand information, user instructions or warnings and applied to the outside of the hang tab.

**IMPORTANT:** Where possible, the RF label should be positioned on the same plane as, and **ALWAYS** within 10 cms (4") of, the product barcode, preferably directly behind it.

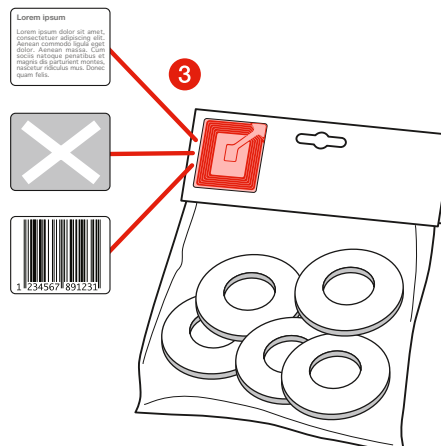
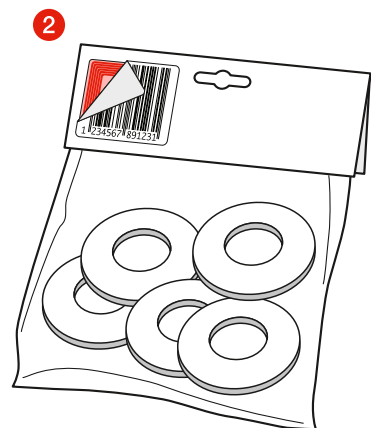

If you have any doubts regarding the suitability of any consumer product or its packaging for RF Source Tagging, please contact your local Checkpoint representative





## SECONDARY PACKAGING

### Recommendations for **metallic** products in **non metallic** packaging 5 Side Boxes

The following recommendations are for metallic products with non metallic secondary packaging e.g. no metal casing, metal foil, metallic ink flood coating, metal back paper etc.

For optimum performance, RF labels should never be applied directly to, or positioned against, metallic or high metal content materials.

Where metallic materials are used for packaging presentation, they should be replaced with Iridine® or MiraFoil® coated materials, or with plain non metallic printed carton or plastic, which allows the RF label to function correctly.

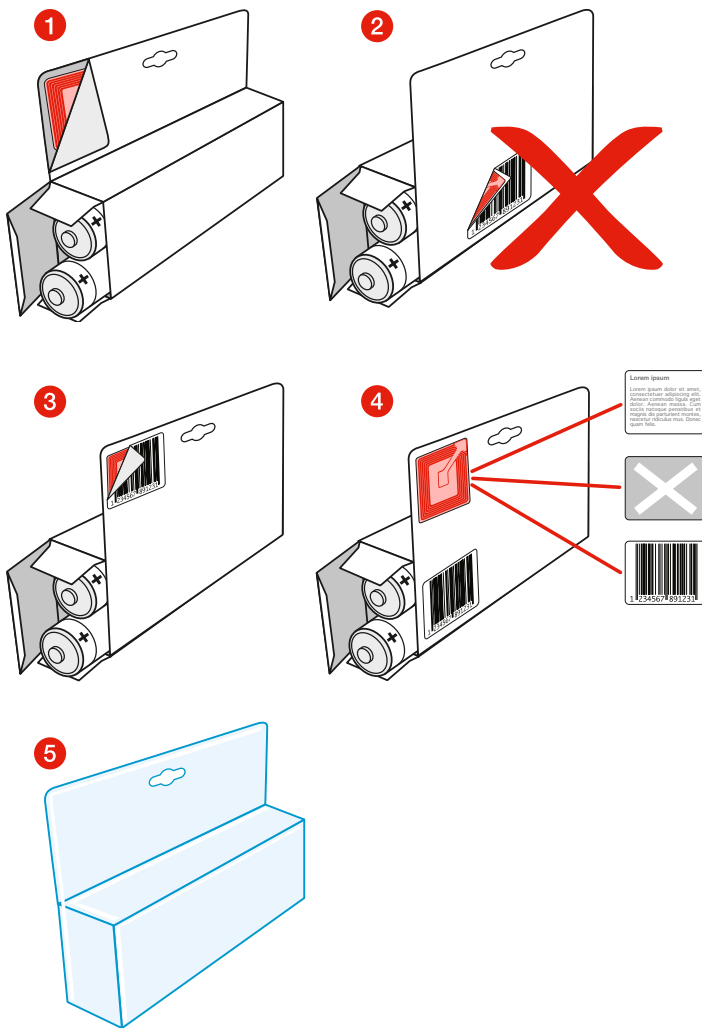

- 1 To ensure correct function, the RF label must always be positioned using the fifth side of the box above the position of the product or any foil packaging, 2 never directly behind it.

Ideally the RF label should be integrated inside the fifth side of the box.

- 3 This makes the protection invisible and increases the effectiveness of the tagging process.

Alternatively, the RF label can be fixed to the exterior and covered with the product or barcode label.

- 4 RF labels can also be overprinted with variable data, brand information, user instructions or warnings.

**IMPORTANT:** Where possible, the RF label should be positioned on the same plane as, and **ALWAYS** within 10 cms (4") of, the product barcode, preferably directly behind it.

- 5 In all cases Checkpoint recommends that any packaging be protected using an ultrasonically sealed security blister, to reduce the risk of tampering.

If you have any doubts regarding the suitability of any consumer product or its packaging for RF Source Tagging, please contact your local Checkpoint representative





Enhanced Performance

## SECONDARY PACKAGING

### Recommendations for **metallic** products in **non metallic** packaging 4 Side Boxes

The following recommendations are for metallic products with non metallic packaging e.g. no metal casing, metal foil, metallic ink flood coating, metal back paper etc.

For optimum performance, RF labels should never be applied directly to, or positioned against, metallic or high metal content materials.

Where metallic materials are used for packaging presentation, they should be replaced with Iridine® or MiraFoil® coated materials, or with plain non metallic printed carton or plastic, which allows the RF label to function correctly.

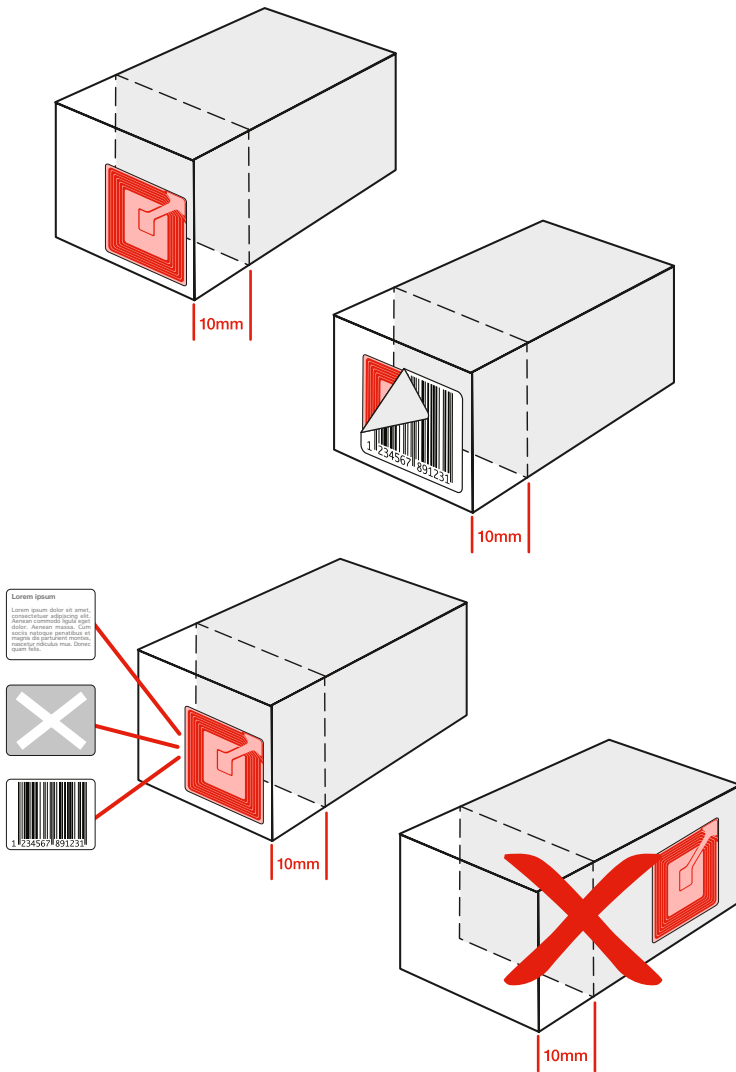

**IMPORTANT:** Checkpoint recommends that a 10 mm gap be created inside the packaging that will separate the metal product or its primary packaging from the RF label.

Alternatively a 5 side box should be used – see page 16.

If this cannot be done, consult your Checkpoint representative for product evaluation and correct positioning.

**IMPORTANT:** Where possible, the RF label should be positioned on the same plane as, and ALWAYS within 10 cms (4”) of, the product barcode, preferably directly behind it.

In all cases Checkpoint recommends that any packaging be protected using an ultrasonically sealed security blister, to reduce the risk of tampering.

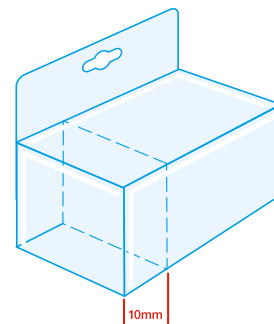

If you have any doubts regarding the suitability of any consumer product or its packaging for RF Source Tagging, please contact your local Checkpoint representative





## SECONDARY PACKAGING

### Recommendations for **metallic** products in **non metallic** packaging Blister Packs

The following recommendations are for metallic products with non metallic packaging e.g. no metal casing, metal foil, metallic ink flood coating, metal back paper etc.

For optimum performance, RF labels should never be applied directly to, or positioned against, metallic or high metal content materials.

Where metallic materials are used for packaging presentation, they should be replaced with Iridine® or MiraFoil® coated materials, or with plain non metallic printed carton or plastic, which allows the RF label to function correctly.

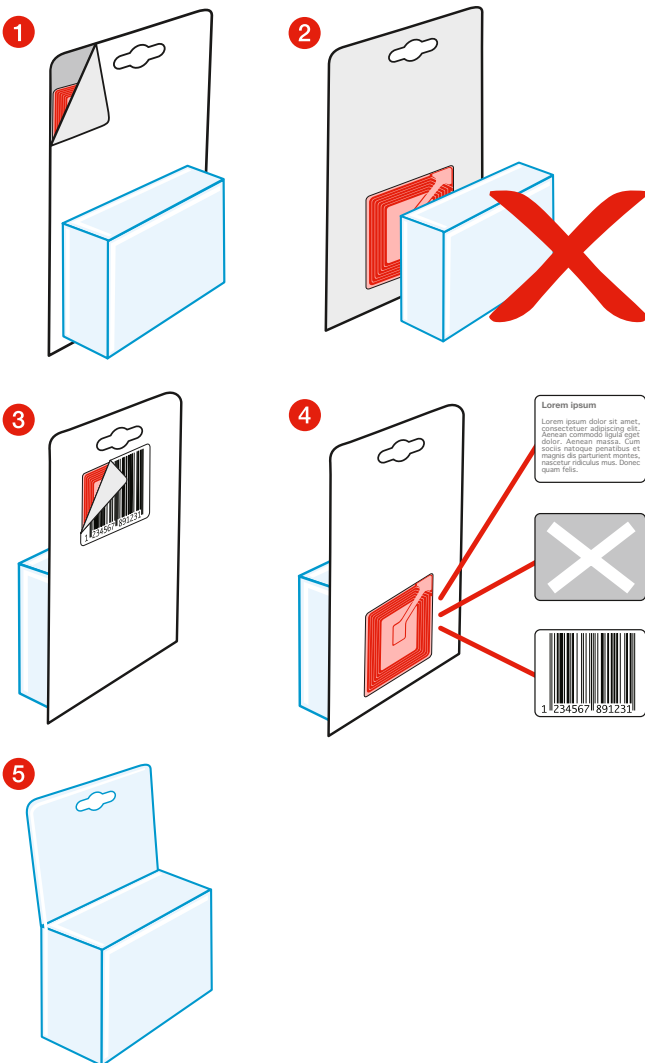

- 1 Always ensure that the RF label is positioned above or below the position of the product, 2 never behind it.

To ensure maximum performance, the RF label should be integrated into the carton presentation card, making the protection invisible and improving the effectiveness of the tagging process.

- 3 Alternatively, the RF label can be fixed to the outside, and covered with a product or barcode label.
- 4 RF labels can also be overprinted with variable data, brand information, user instructions or warnings and applied to the outside of the blister packaging.

**IMPORTANT:** Where possible, the RF label should be positioned on the same plane as, and **ALWAYS** within 10 cms (4") of, the product barcode, preferably directly behind it.

- 5 In all cases Checkpoint recommends that any packaging be protected using an ultrasonically sealed security blister, to reduce the risk of tampering.

If you have any doubts regarding the suitability of any consumer product or its packaging for RF Source Tagging, please contact your local Checkpoint representative





Enhanced Performance

## SECONDARY PACKAGING

### Recommendations for **metallic** products in **non metallic** packaging DIY/O&M Plastic Tubs

The following recommendations are for metallic products with non metallic secondary packaging e.g. no metal casing, metal foil, metallic ink flood coating, metal back paper etc.

For optimum performance, RF labels should never be applied directly to, or positioned against, metallic or high metal content materials.

Where metallic materials are used for packaging presentation, they should be replaced with Iridine® or MiraFoil® coated materials, or with plain non metallic printed carton or plastic, which allows the RF label to function correctly.

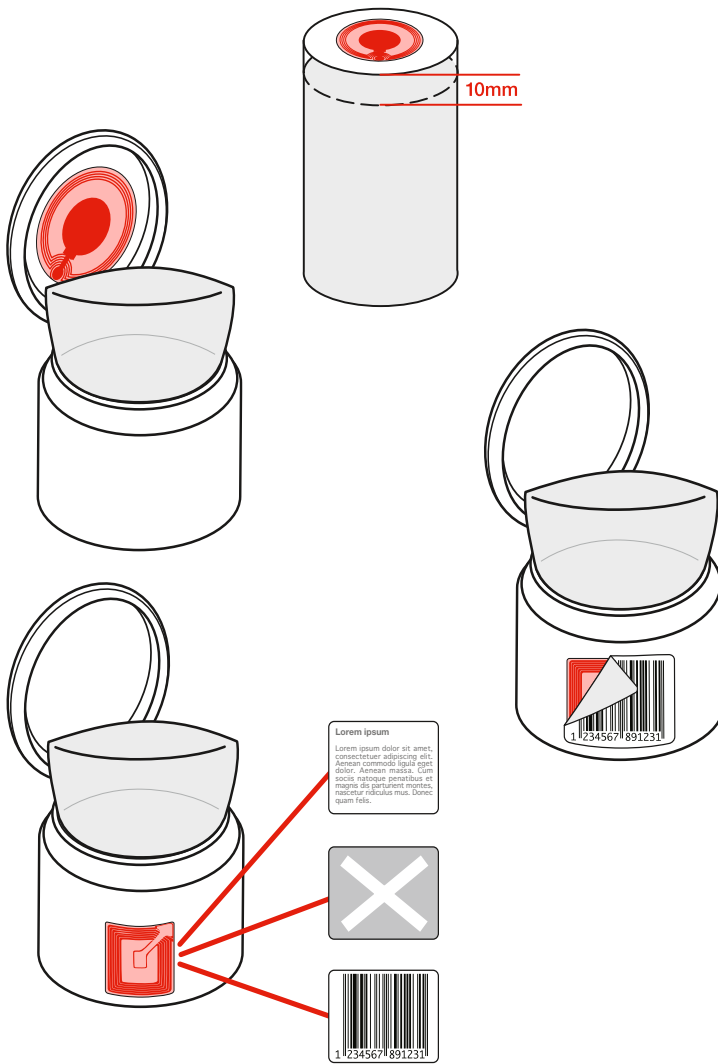

For correct RF label function there must be a space of 10mm or more between the product and the RF label

**IF THIS CONDITION IS MET**, the RF label can be applied directly to the outside of product packaging and covered with the normal product or barcode label.

Alternatively, RF labels can be overprinted with variable data, brand information, user instructions or warnings and applied to the outside of the carton packaging.

**IMPORTANT:** Where possible, the RF label should be positioned on the same plane as, and **ALWAYS** within 10 cms (4”) of, the product barcode, preferably directly behind it.

If you have any doubts regarding the suitability of any consumer product or its packaging for RF Source Tagging, please contact your local Checkpoint representative





## SECONDARY PACKAGING

### Recommendations for **metallic** products in **non metallic** packaging Plastic Carry Cases

The following recommendations are for metallic products with non metallic packaging e.g. no metal casing, metal foil, metallic ink flood coating, metal back paper etc.

To ensure optimum performance, RF labels should never be applied directly to, or positioned against, metallic or high metal content materials.

Where metal foil or metallic ink flood coating is used for packaging presentation, it should be replaced with Iridine® or MiraFoil® coated materials that allow the RF label to function correctly.

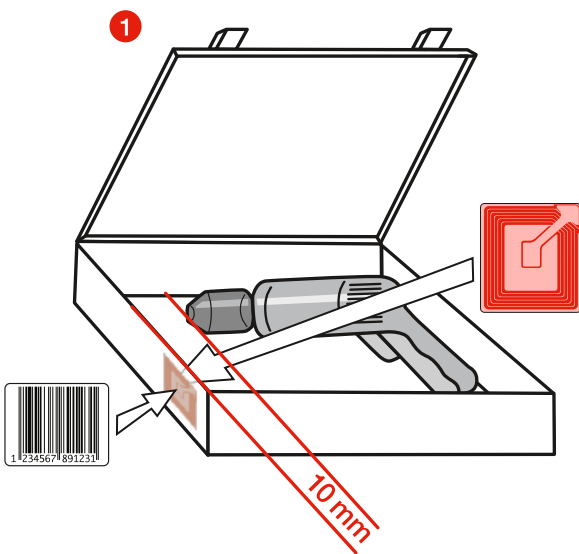

- 1 Products presented in plastic carry cases are typically tagged by fixing an RF label to the inside wall of the case directly behind or within 10 cms (4") of the barcode position. Care should be taken to ensure no metal parts are within 10mm of the RF label.
- 2 Alternatively, the RF label can be fixed to the outside and covered with the product or barcode label.
- 3 RF labels can also be overprinted with variable data, brand information, user instructions or warnings and applied to the outside of the plastic case.

**IMPORTANT:** Where possible, the RF label should be positioned on the same plane as, and ALWAYS within 10 cms (4") of, the product barcode, preferably directly behind it.

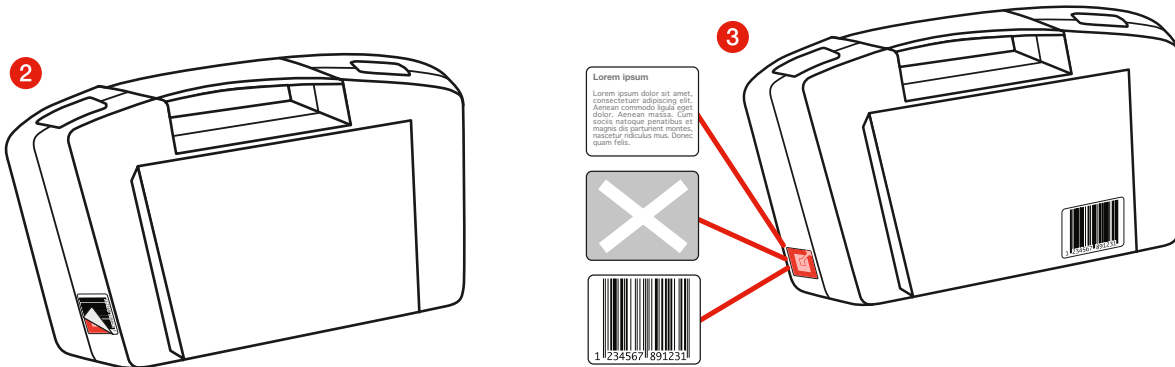

If you have any doubts regarding the suitability of any consumer product or its packaging for RF Source Tagging, please contact your local Checkpoint representative





Enhanced Performance

## SECONDARY PACKAGING

### Recommendations for **metallic** products in **metallic** packaging Metal Carry Cases

#### Important

Please note that metal carry cases must **not be protected** using standard RF labels.

To ensure optimum performance, RF labels should never be applied directly to, or positioned against, metallic or high metal content materials.

If metal carry cases must be used for presenting merchandise then the form of protection to be used is a loop or lanyard hard tag.

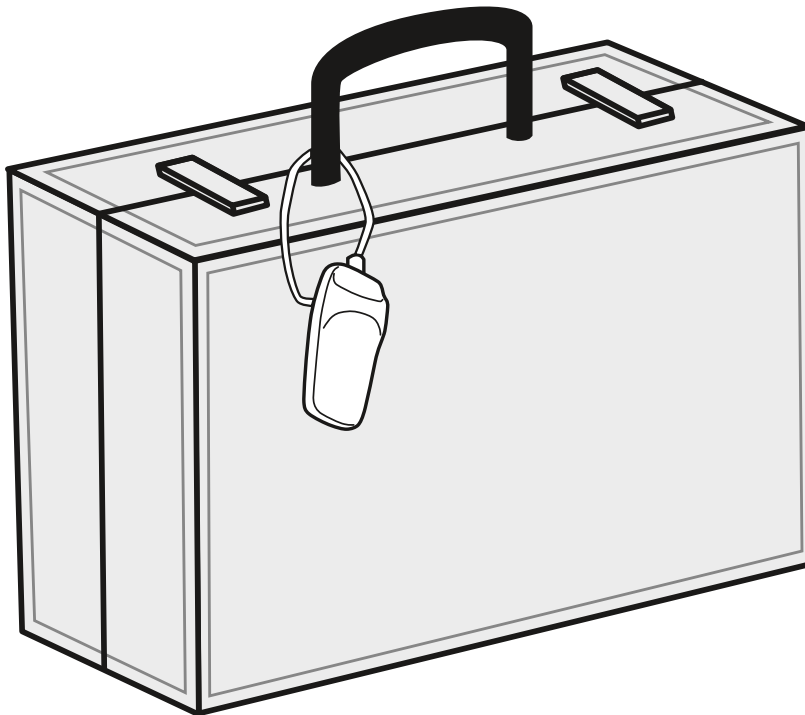

If you have any doubts regarding the suitability of any consumer product or its packaging for RF Source Tagging, please contact your local Checkpoint representative



Checkpoint Systems is a global leader in shrink management, merchandise visibility and apparel labelling solutions. Checkpoint partners with retailers and their suppliers to reduce shrink, increase shelf availability, ensure labelling consistency and achieve operational excellence. Checkpoint's solutions enable retailers to enhance the shopping experience for consumers, and grow their businesses profitably.

Electronic Article Surveillance



Solutions @ Source



High-Theft Solutions



Shrink Management Software



Merchandise Visibility



Apparel Labelling Solutions



Video, Alarm and Monitoring Services



Retail Merchandising Solutions

CONTACT  
Solutions\_Source@checkpt.com

