

# ***SOLUTIONS@SOURCE***

## ***Shirts & Blouses Guidelines***



GEN-SHIRTS\_V01\_100910



Enhanced  
Performance

## POCKET TAG

- The Pocket Tag is the recommended application for almost any type of garment.
- The Pocket Tag should always be sewn into the left seam of the garment behind the care label (place as illustrated).
- Pocket Tags are designed to be separated from the garment before use – they should not stay with the garment during normal wear.



Pocket Tags should be sewn in together with the care label.

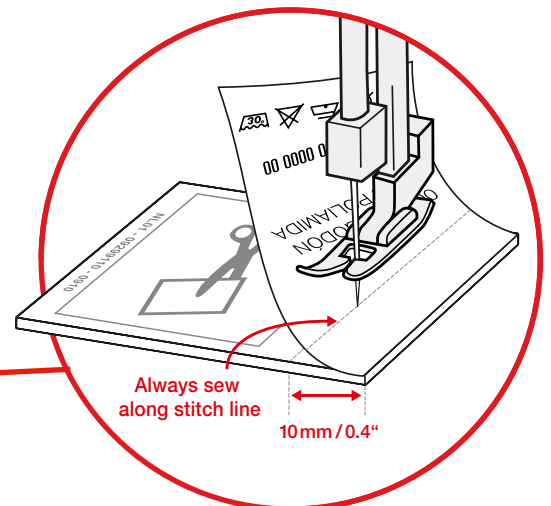

For any questions regarding this or any other labelling process contact your local Checkpoint representative.

All rights reserved © Checkpoint Systems Inc. Thorofare, USA 2010.  
All information and illustrations are intellectual property of Checkpoint Systems Inc.  
Any copying, reprinting, manipulating or publishing in part or in whole is strictly prohibited.





Enhanced  
Performance

## FIT TAG

- RF FIT (Radio Frequency Fully Integrated Tag) Tags are recommended for use with those apparel garments and accessories that cannot be protected using the Drop In, Pocket Tag, Hard Tags or adhesive RF labels.
- The FIT Tag's shape and colour can be fully customised (size, colour, material etc.) according to client requirements.
- Unless otherwise stated RF FIT Tags should always be applied to the LEFT side of the garment.



For any questions regarding this or any other labelling process contact your local Checkpoint representative.



## HARD TAG

- Hard Tags are highly recommended for use with apparel garments and accessories as a visual deterrent.
- In general they are not recommended for finer fabrics such as silk or lycra.
- Checkpoint offers a Hard Tag solution that is specifically designed to travel with the garment from source to store.

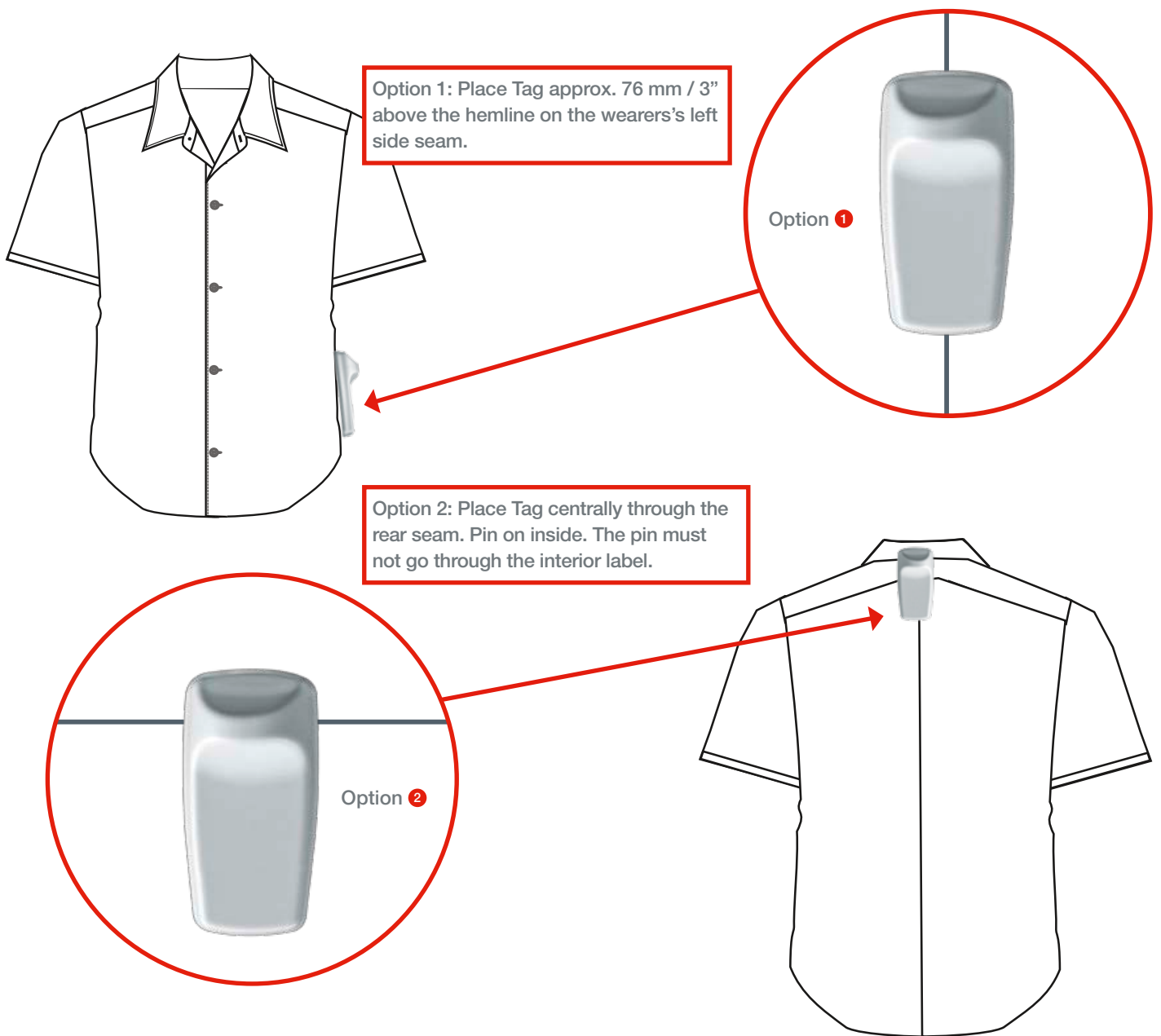

For any questions regarding this or any other labelling process contact your local Checkpoint representative.



## DROP IN TAG

- The Drop In Tag is recommended for use with any type of garment with pockets closed by a button, zipper or temporary stitch.
- Drop In Tags should be positioned in such a way that the consumer can easily remove them before using the garment.
- Drop In Tags are designed to be removed from the garment before use – they should not stay with the garment during normal wear.

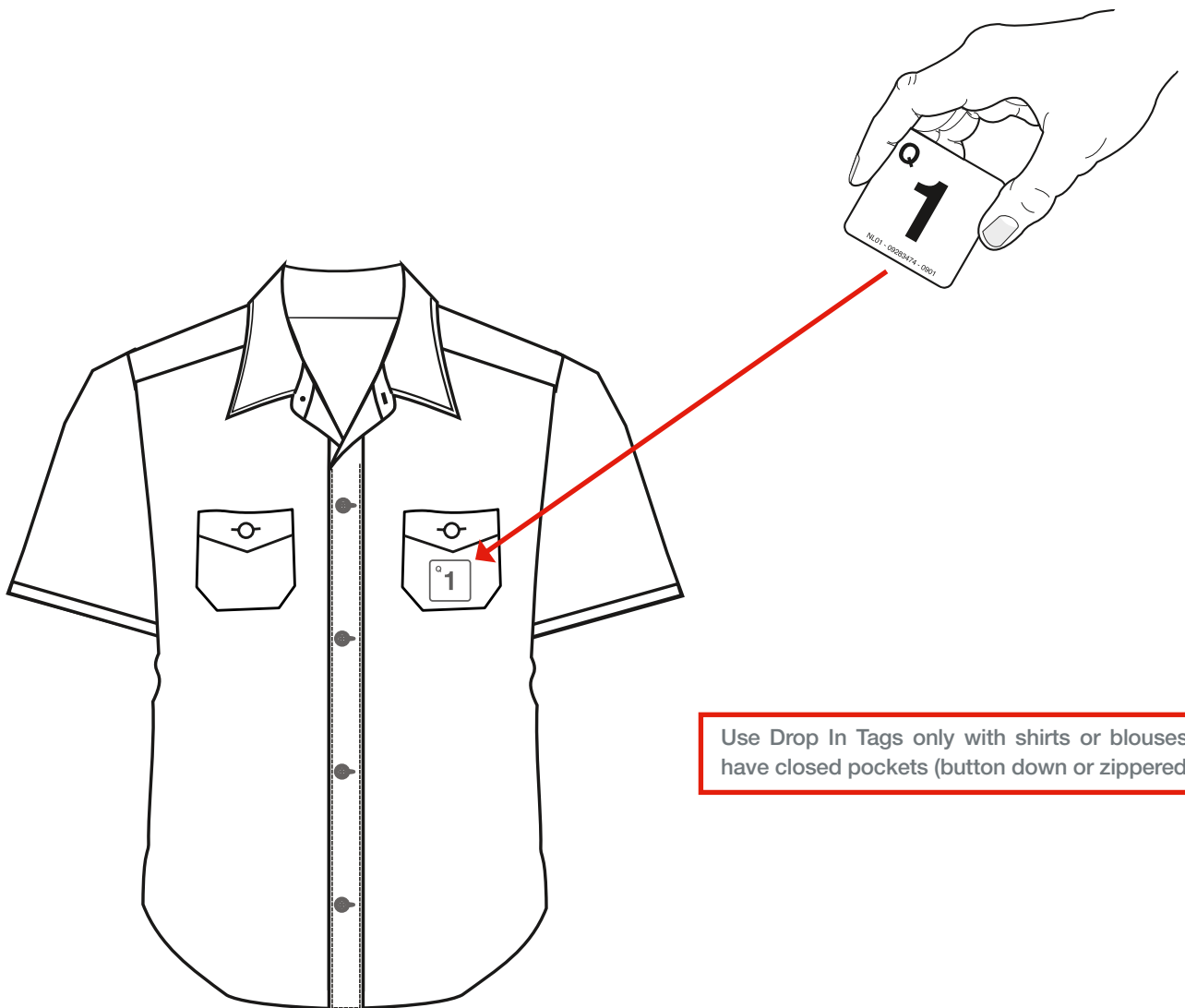

Use Drop In Tags only with shirts or blouses that have closed pockets (button down or zippered).

For any questions regarding this or any other labelling process contact your local Checkpoint representative.





## FLAT PACKED

### POCKET TAG

- The Pocket Tag is the recommended application for almost any type of garment.
- The Pocket Tag should always be sewn into the left seam of the garment behind the care label (place as illustrated).
- Pocket Tags are designed to be separated from the garment before use – they should not stay with the garment during normal wear.

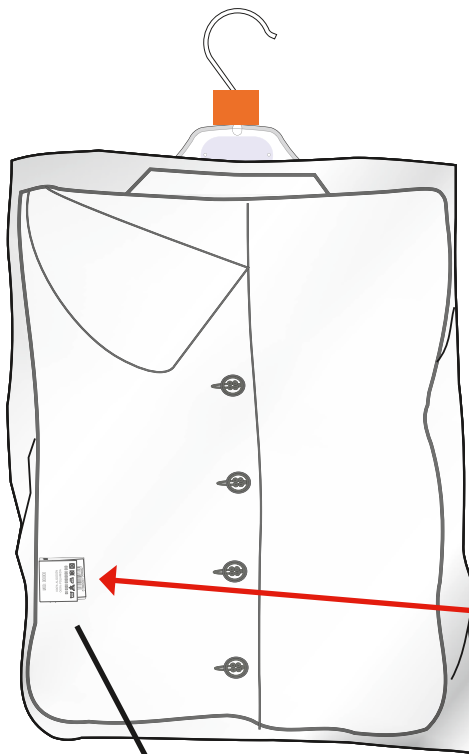

Pocket Tags should be sewn in together with the care label.

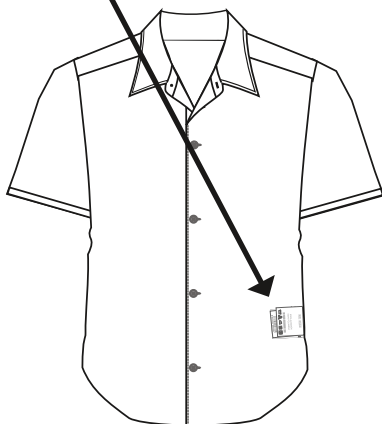
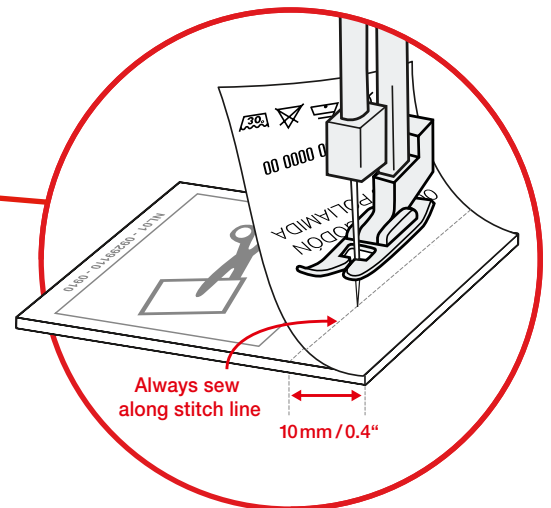

For any questions regarding this or any other labelling process contact your local Checkpoint representative.





Enhanced Performance

## FLAT PACKED

Shirts and other garments presented in flat packaging should be protected by fixing the RF Labels to the carton support board used to pack the product and maintain its form.

The RF Label should always be placed within 10 cms of the barcode price label. Preferably directly behind it.

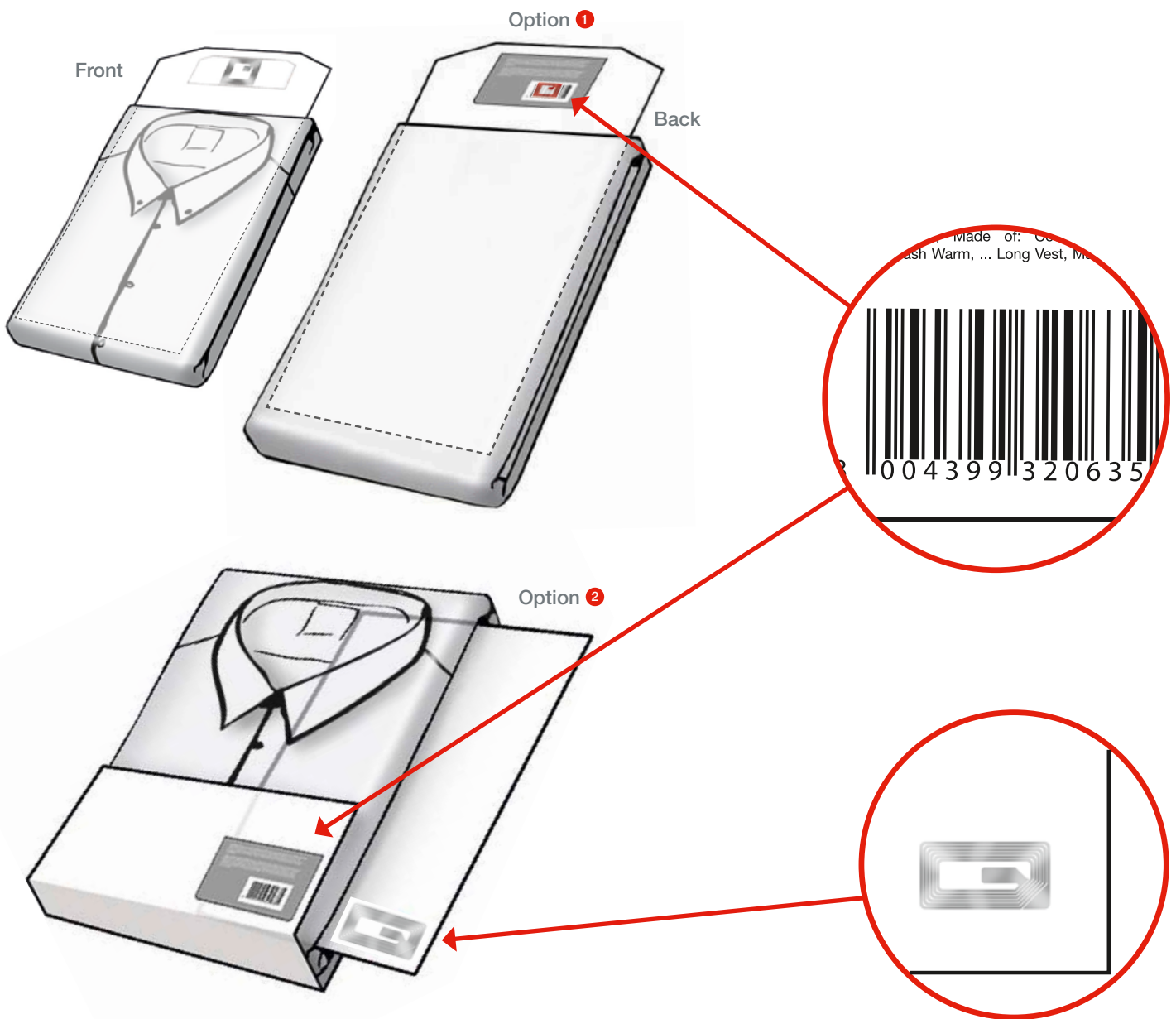

RF Labels must NEVER be placed on, underneath or inside metal products or packaging materials  
– This includes metallic foils, labels printed with metallic inks, metalback paper labels, foil backed flexible packaging, metal presentation tubes etc.

For any questions regarding this or any other labelling process contact your local Checkpoint representative.



Checkpoint Systems is a global leader in shrink management, merchandise visibility and apparel labelling solutions. Checkpoint partners with retailers and their suppliers to reduce shrink, increase shelf availability, ensure labelling consistency and achieve operational excellence. Checkpoint's solutions enable retailers to enhance the shopping experience for consumers, and grow their businesses profitably.

Electronic Article Surveillance



Solutions @ Source



High-Theft Solutions



Shrink Management Software



Merchandise Visibility



Apparel Labelling Solutions



Video, Alarm and Monitoring Services



Retail Merchandising Solutions

CONTACT  
Solutions\_Source@checkpt.com

